

RFW Faltwand wandmontiert | Paravent rigide montage mural | Folding Wall wall-mounted
RFW-FG Faltwand fahrbar | Paravent rigide Version mobile | Folding Wall mobile version

Montageanleitung | Gebrauchsanweisung | Fehlerhafte Anwendungen | Wartung & Pflege | Technische Daten
Instructions de montage | Notice d'utilisation | Mauvaises manipulations | Maintenance & entretien | Données techniques
Installation instructions | General use | Incorrect Usage | Maintenance & cleaning | Technical Information

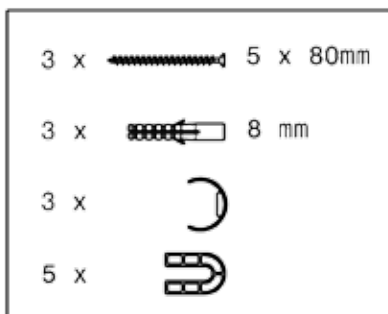

Montageanleitung | Instructions de montage | Installation instructions



Achtung!
Schrauben und Dübel sind nur für den Einsatz in Vollbaustoffen und Hohlkammersteinen geeignet. Bei anderen Wänden sind Spezialdübel zu verwenden!

Attention !
Les vis et chevilles livrées sont compatibles avec les murs pleins ou en parpaings. Pour d'autres types de murs veuillez vous munir de chevilles adaptées

Caution!
Screws and anchors are suitable for use in solid construction materials and bricks/cinderblocks with hollow chambers. Use special anchors for all other types of walls!

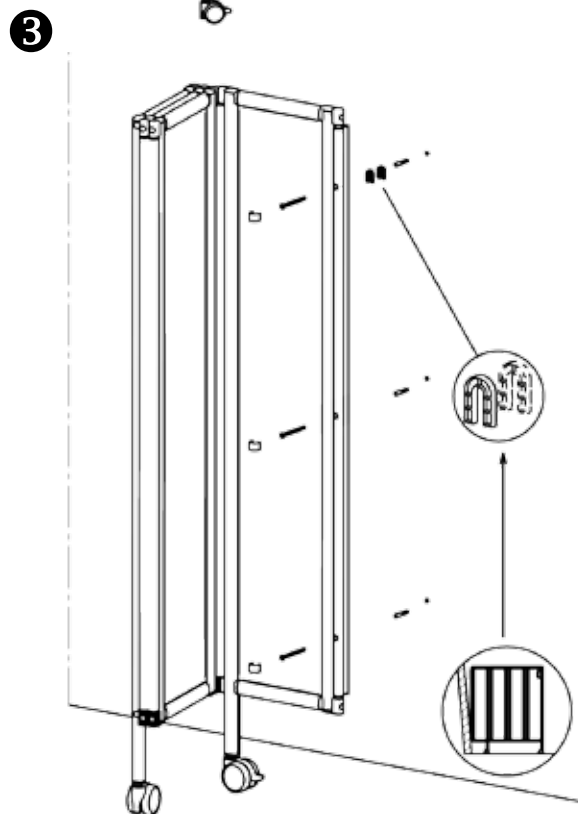
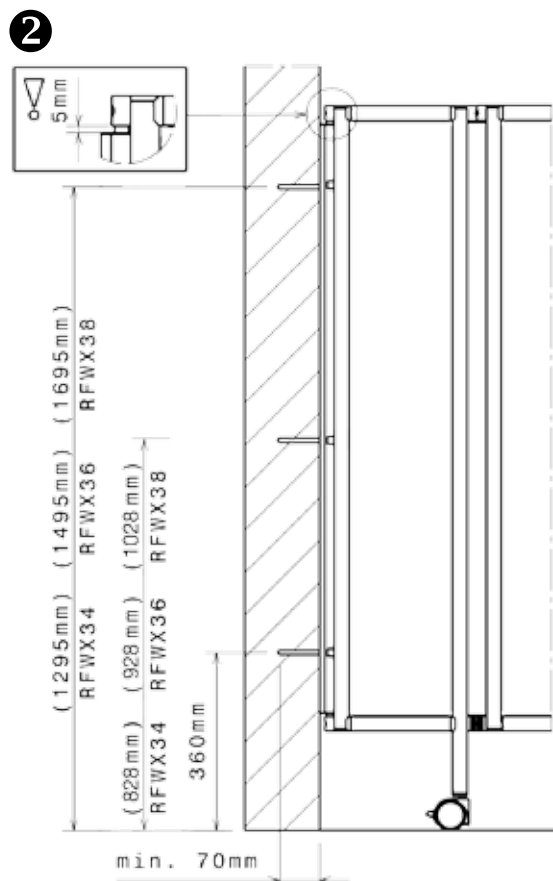
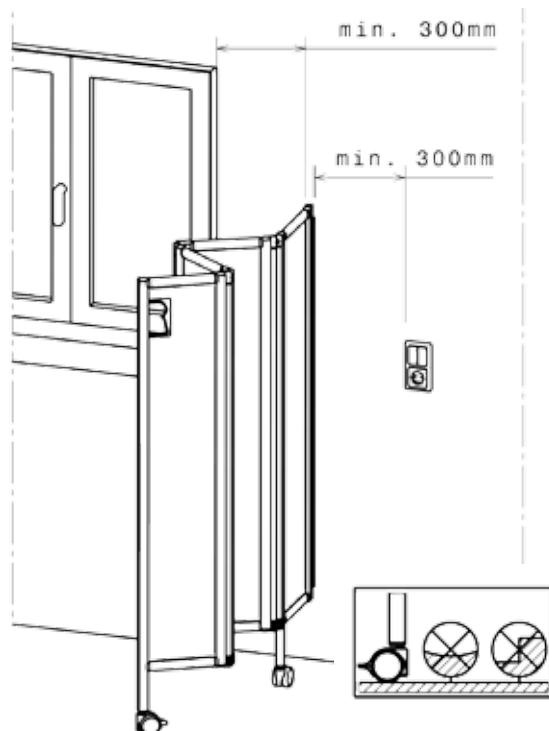
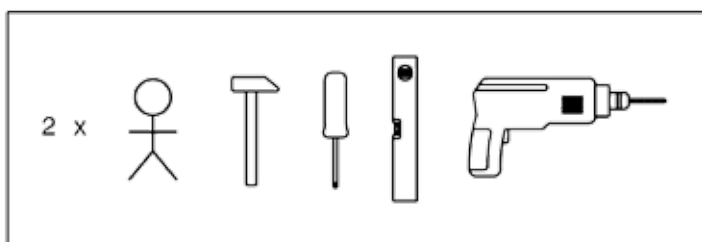

Montageanleitung | Instructions de montage | Installation instructions

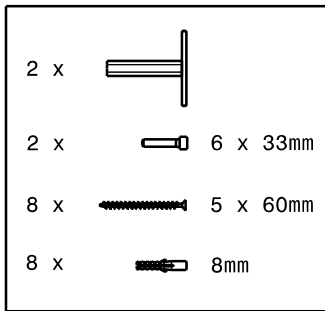
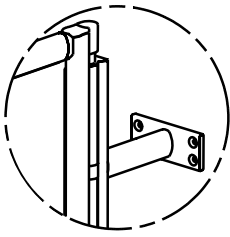

Achtung!

Schrauben und Dübel sind nur für den Einsatz in Vollbaustoffen und Hohlkammersteinen geeignet. Bei anderen Wänden sind Spezialdübel zu verwenden!

Attention !

Les vis et chevilles livrées sont compatibles avec les murs pleins ou en parpaings. Pour d'autres types de murs veuillez vous munir de chevilles adaptées

Caution!

Screws and anchors are suitable for use in solid construction materials and bricks/cinderblocks with hollow chambers. Use special anchors for all other types of walls!

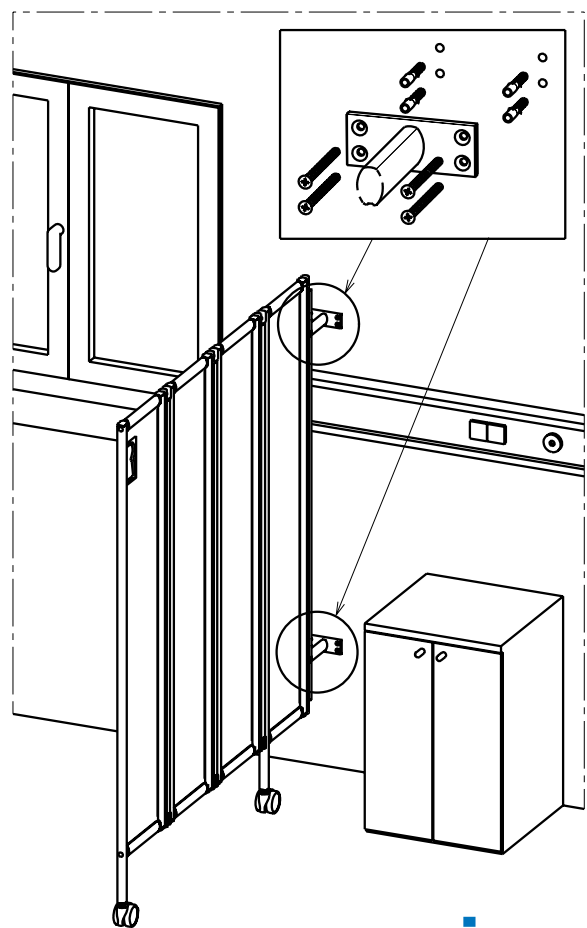
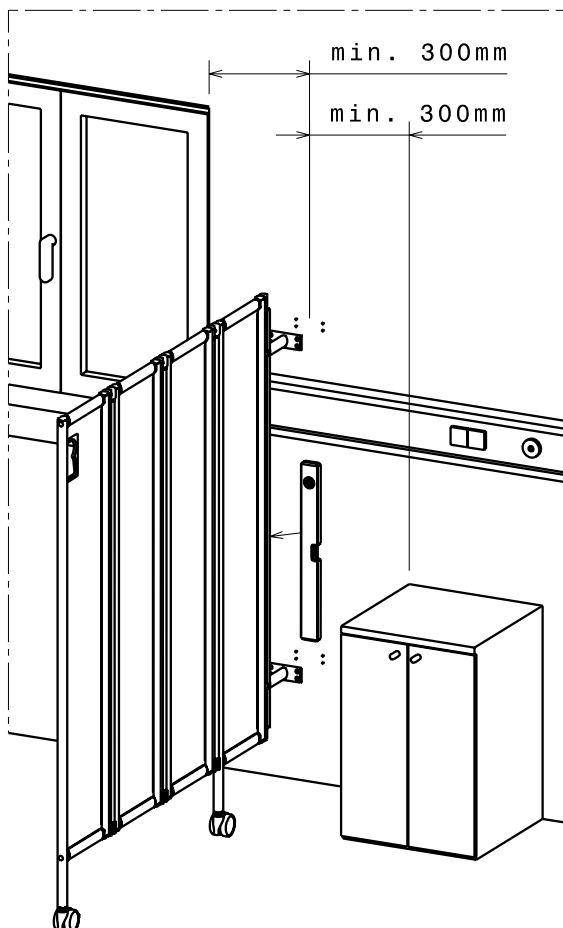
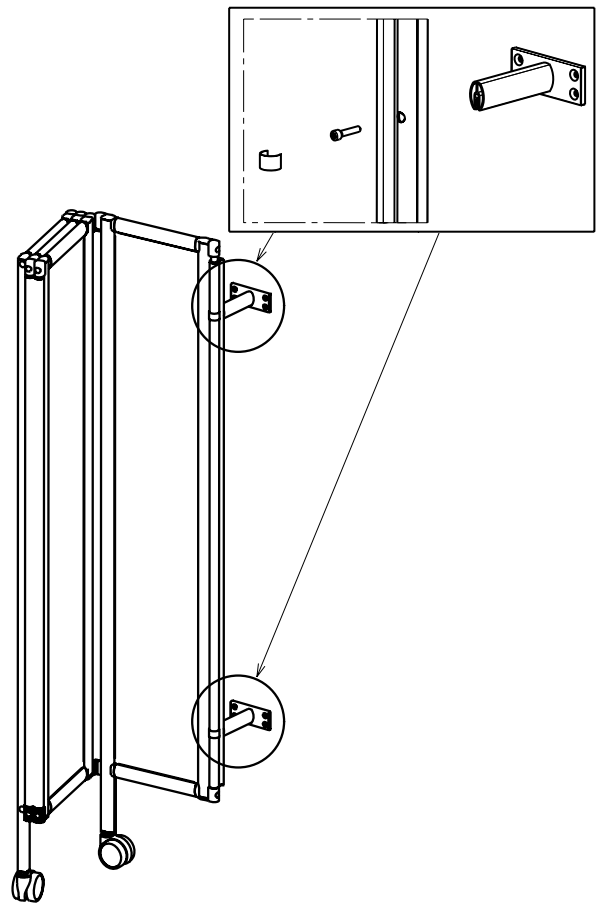
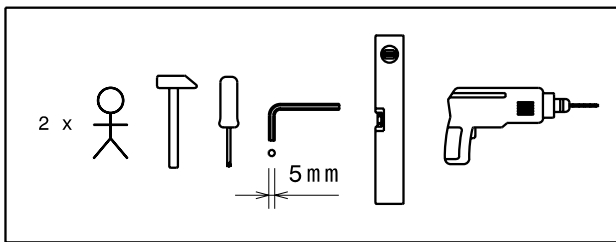

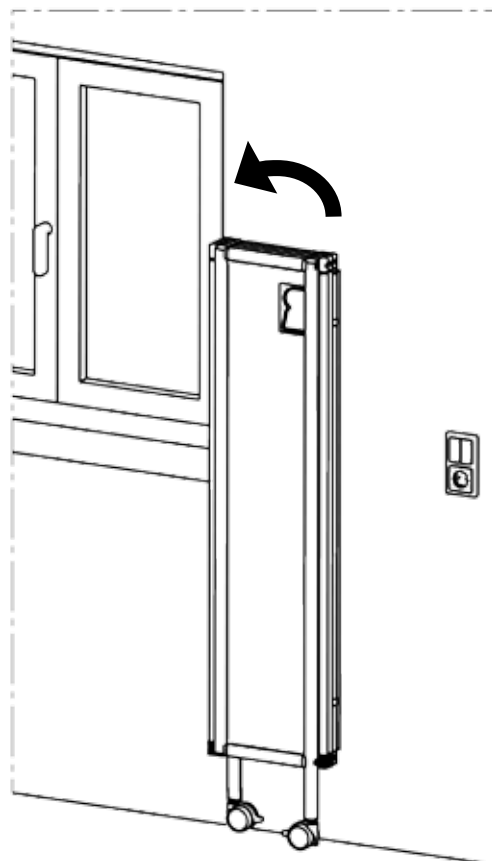
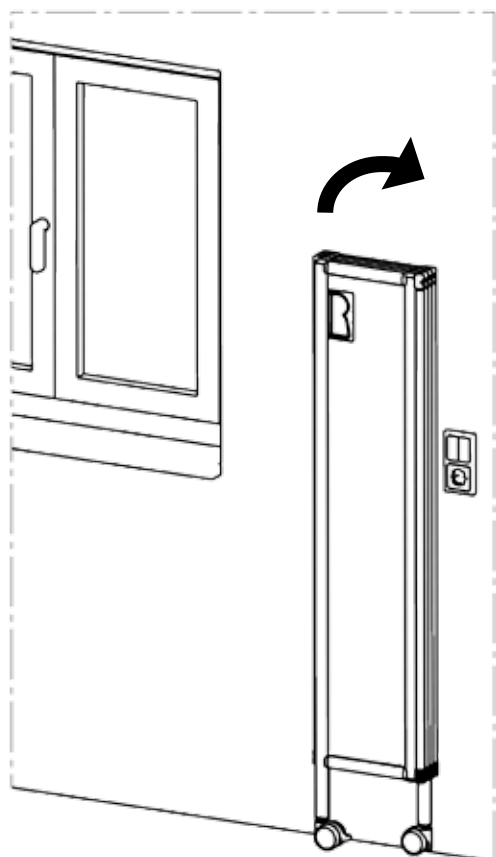

1. Faltwand kann nach links oder rechts in Parkposition gebracht werden

1. Le paravent rigide peut se ranger au mur du côté gauche ou droit

1. You can fold the folding wall away, to either the left or right hand side

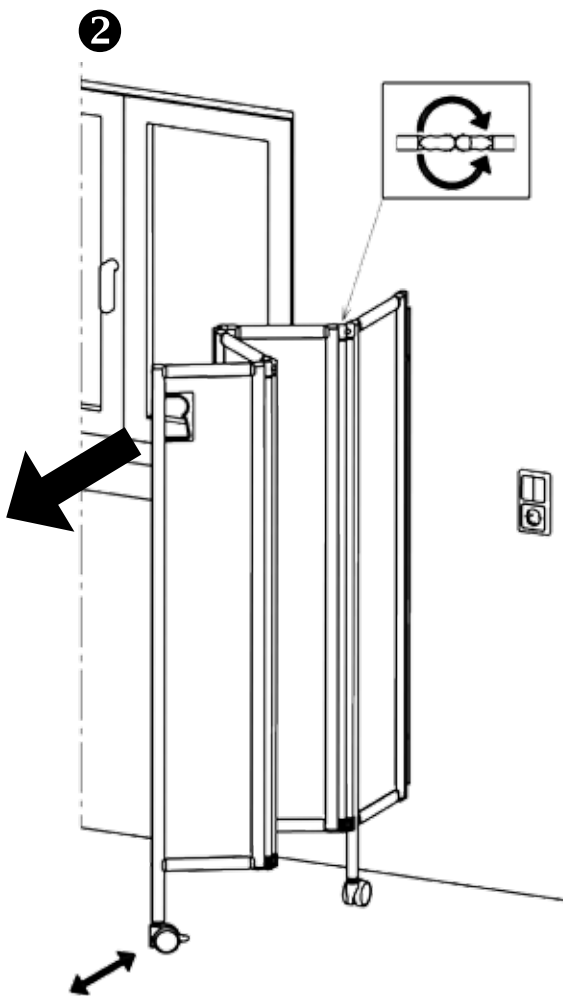

2. Faltwand vom Griff her ausziehen und in gewünschte Position bringen

2. Tirer le paravent rigide vers soi et le ramener dans la position souhaitée

2. With the aid of the handle, open the folding wall to the required position

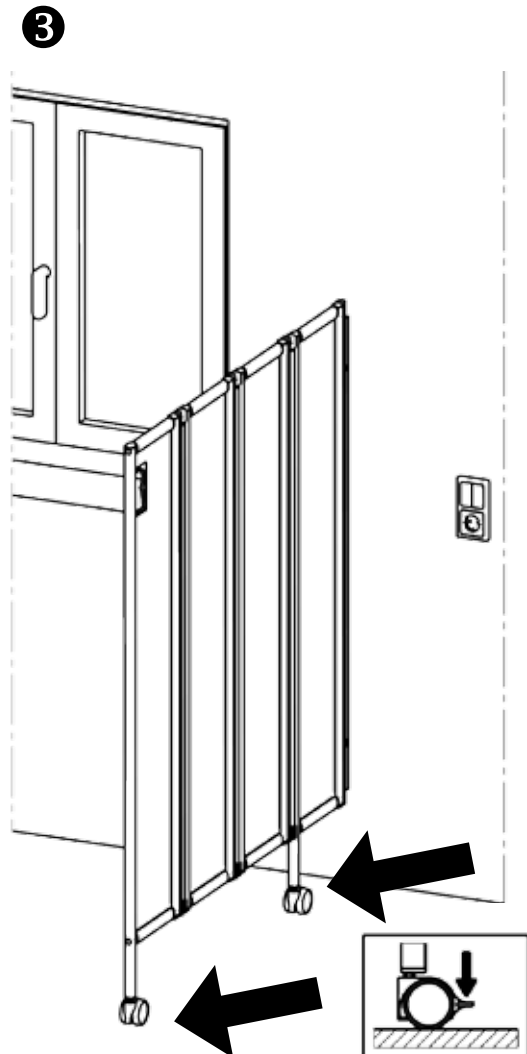

3. Zur Gewährleistung der Standsicherheit müssen nach Ausrichtung der Faltwand **alle** Rollen angebremsst werden

3. Quand le paravent est dans la position souhaitée - bloquer **toutes les** roulettes à l'aide du frein

3. When positioned correctly, lock **all the** castors

Fehlanwendungen | Mauvaises manipulations | Incorrect Use



Ropimex Faltwände dienen ausschließlich als Sichtschutz und Raumtrennung im Innenbereich.

Ropimex paravent rigide : protection des regards et séparateur de pièce intérieur.

Ropimex Folding Walls are only for use as a privacy screen and/or an interior room divider.

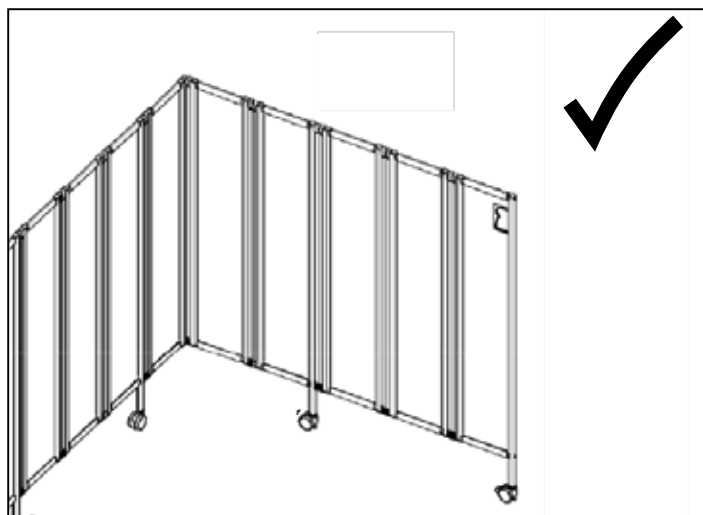
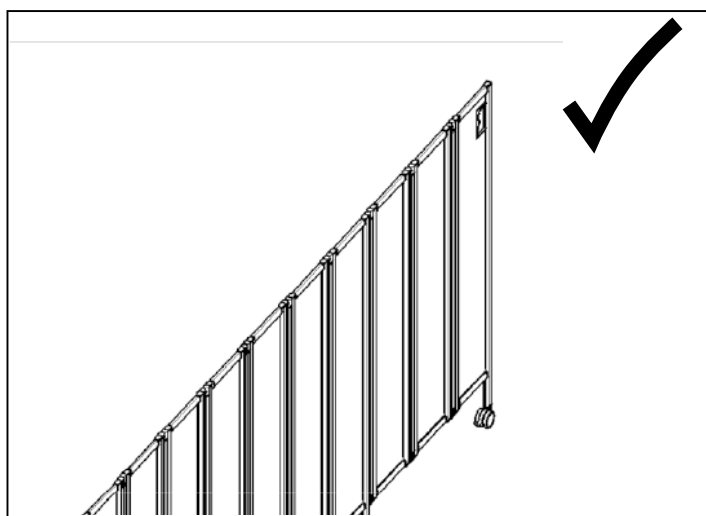

Fehlanwendungen | Mauvaises manipulations | Incorrect Use

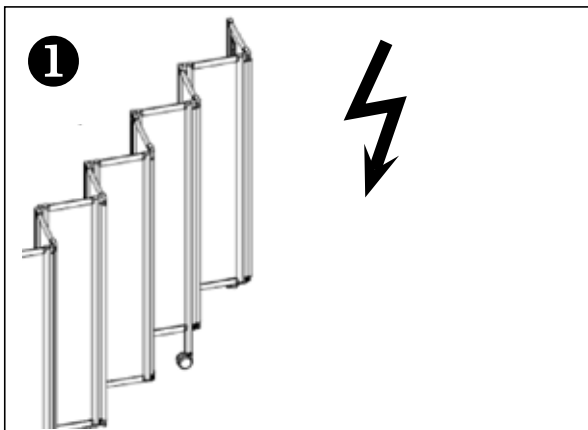
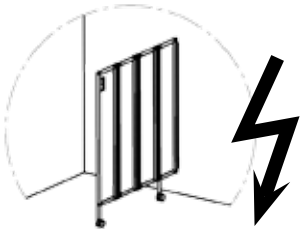

Nicht im Zick-Zack aufstellen!

Ne pas positionner en zick-zack !

Do not use in a zigzag position!

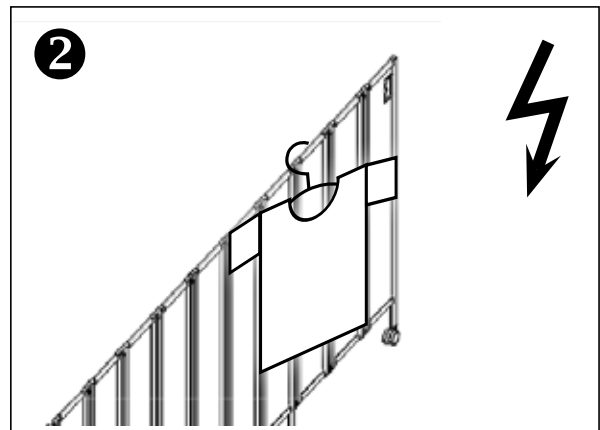

Nicht als Ablage verwenden!

Ne pas utiliser en support !

Do not hang anything from the Folding wall!

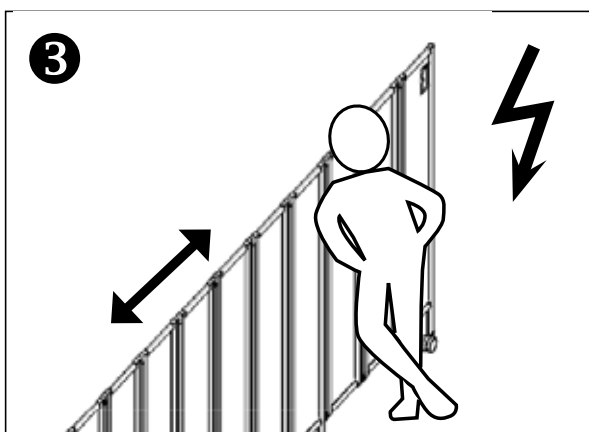

Nicht anlehnen!

Ne pas s'appuyer contre !

Do not lean against the folding wall!

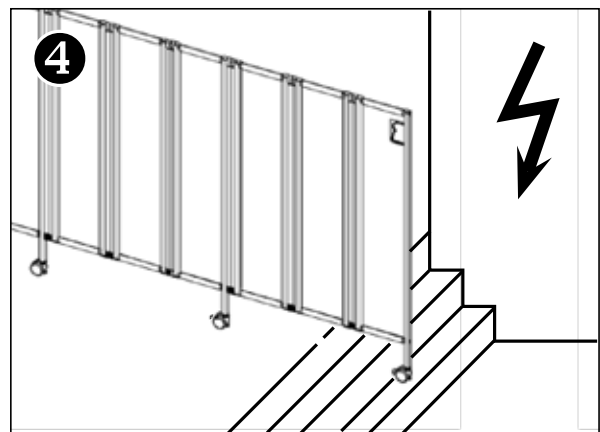

Anwendung nur auf ebener Fläche!

Utilisation uniquement sur une surface plane!

Use it only on level surfaces !

Wartung

ropimex® Faltwände sind wartungsfrei. Wir empfehlen, den festen Sitz des Wandanschlusses und die Funktion der Laufräder regelmäßig zu prüfen.

Pflege

Alle Teile der Faltwand (Paneele, Rahmen und Rollen) können gereinigt oder desinfiziert werden mit allen üblichen Desinfektionsmitteln / Reinigern (wasserbasiert und alkoholbasiert). Dampfdesinfektion ist möglich.

Maintenance

Les paravents rigides ropimex® ne nécessitent pas de maintenance. Nous conseillons uniquement de vérifier de temps à autre que les fixations murales soient bien en place ainsi que l'état des roulettes.

Entretien

Toutes les parties du paravent rigide peuvent être nettoyées et désinfectées à l'aide de produits d'usage courant (à base d'eau ou alcool). La désinfection à la vapeur est possible.

Maintenance

The ropimex® Folding Wall does not need any routine maintenance. We advise that the fixing to the wall is regularly checked for security, along with the correct functioning of the castors

Cleaning

All parts from the folding wall (panel, frame and wheels) can be cleaned or disinfected with usual products (waterbased or alcoholbased). Steam disinfection is possible.

Technische Daten | Technical Information | Données techniques

Variante / Modell / modèle :	wandmontierte Faltwand / Folding wall fixed to the wall Paravent rigide montage mural
Flügelbreite / Panel width / Largeur par battant:	generell / standard / en général 300 mm
Höhen / Height / Hauteur:	1.450 mm, 1.650 mm, 1.850 mm
Gewicht / Weight / Poids:	1.450 mm = 3,0 kg/Flügel / Panel / battant 1.650 mm = 3,5 kg/Flügel / Panel / battant 1.850 mm = 4,0 kg/Flügel / Panel / battant

Materialien / Materials / Matériau

Rahmenteile und Scharnierteile: Frames and hinges: Contours et charnières:	stranggepresstes Aluminium (Al Mg Si 05), eloxierte Oberfläche anodised aluminium (Al Mg Si 05) en aluminium anodisé (Al Mg Si 05)
Kunststoffteile / Plastic parts / Pièces plastiques:	PA 6 GF 15 Polyamid mit 15% Glasfasern Polyamide PA 6 GF of which 15% fibreglass Polyamide PA 6 GF 15 comprenant 15% de fibres de verre
Füllplatten / Panels / Plaques:	Polycarbonat 2 mm weiß transluzent, schwer entflammbar Baustoffklasse DIN EN 13501-1, B-s1 d2, extrem schlagzäh Polycarbonate 2 mm thick, white, translucent, flame retardant DIN EN 13501-1, B-s1 d2, scratch resistant Polycarbonate 2 mm blanc translucide, difficilement inflammable classe DIN EN 13501-1, B-s1 d2, excellente résistance aux rayures
Farben/Design / Colored/Design Couleur/Design:	Standard: weiß, transluzent, farbige Gestaltung mittels Folierung in 10 Farben, 4 Designs, flügelweise Farbgestaltung möglich. Standard: white, translucent, 10 different colours, 4 designs. Each panel can be individually coloured. Standard : blanc, translucide, film de couleur posé sur le battant Film disponible en 10 couleurs, 4 Designs, couleur différente par battant possible
Rollen/Wheels/Rouletes:	Faltwand / Folding wall / Paravent rigide: Ø 65 mm Fahrgestell / Trolley / Chassis: Ø 75 mm Stützrollen / small wheels / Roulettes intermédiaires: Ø 50 mm

Blickdichtes Scharnier erlaubt Flügeldrehungen bis 360°,
Ausführung von 3 bis 10 Flügel, nachträgliche Erweiterung möglich.

Hinges rotate 360° and leave no visible gap between panels.
Available from 3 to 10 panels, the number of leaf sections can be extended later as required

Charnières ne laissant passer aucun champs visuel et pivotant à 360°
Disponible de 3 à 10 battants, rallongement ultérieur possible



Montageanleitung | Bedienungsanleitung ropimex Faltwand mit Stützsystem

Instructions de montage | Mode d'emploi du paravent rigide ropimex version mobile

Installation instructions | Operating Instructions for the ropimex Folding Wall (Mobile version)



Montageanleitung | Instructions de montage | Installation instructions

Istruzioni di montaggio
Fitting Instructions
Fiche d'installation
Instrucciones de uso

Instruções de montagem
Montagevoorschriften
Monteringsvejledning
Monteringsanvisningar

Utrustning instruksjoner
Asennusohjeet
Διαρρύθμιση οδηγίες
Montáž

Navodila za vgradnjo
Instrukcje montażu
Монтажные инструкции
Montaj talimatları

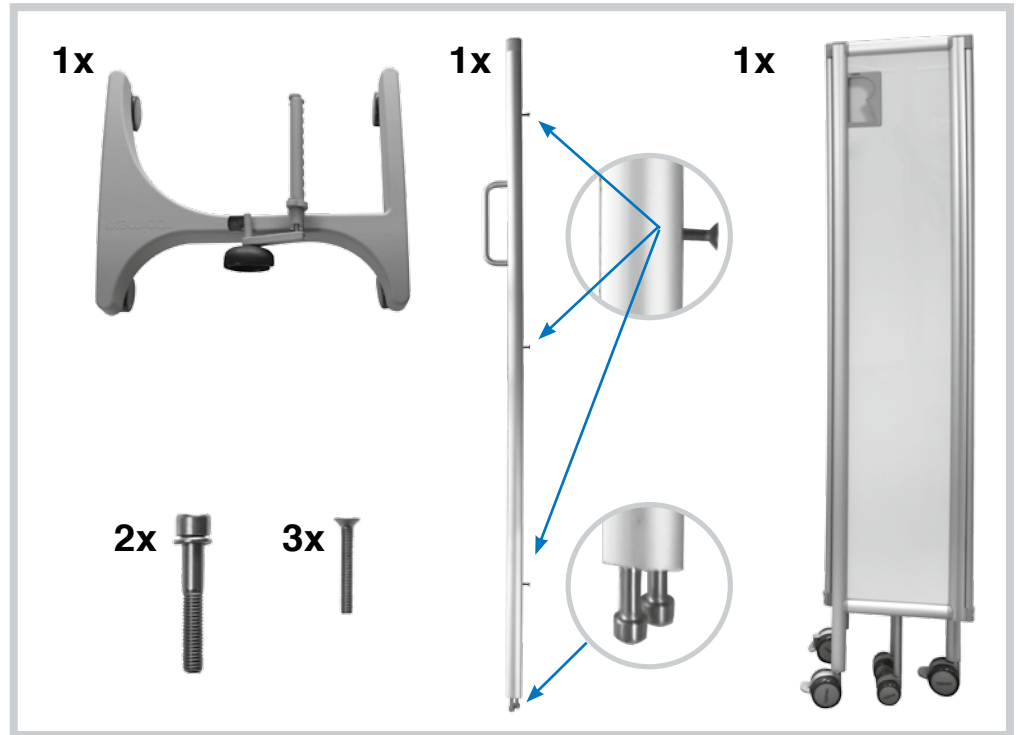
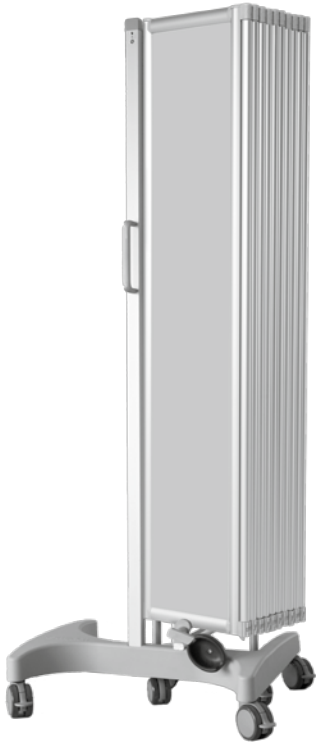

A

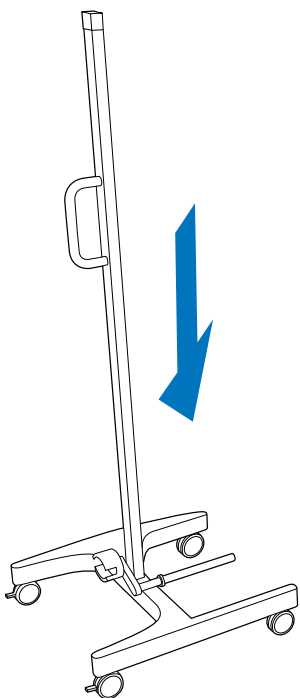

B

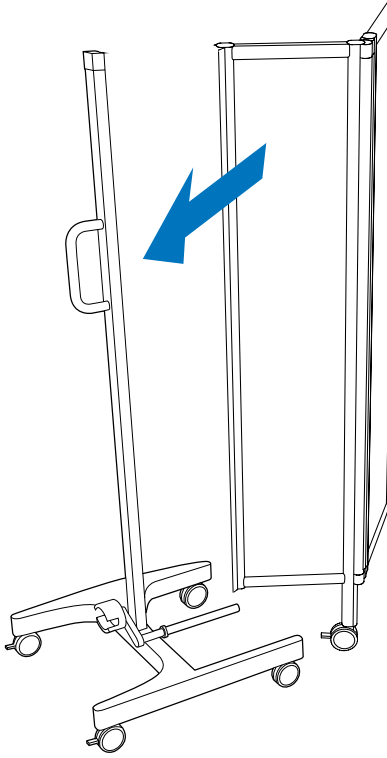

Aufstellen der faltwand

Wheel the folding wall into the required location

Placer le paravent rigide



- 1** faltwand positionieren
Position the folding wall
Positionner le paravent rigide

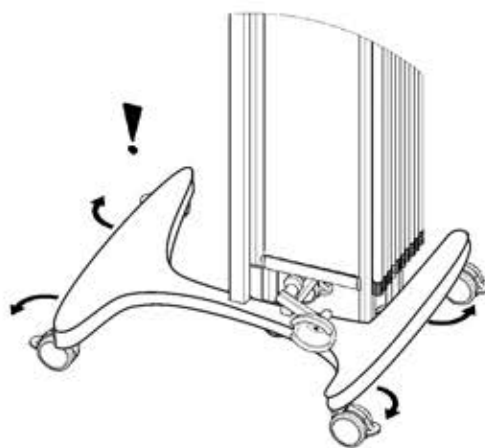

- 2** Alle vier Lenkrollen nach außen drehen
Rotate the castors so that the locks face outwards
Positionner les 4 roulettes vers l'extérieur

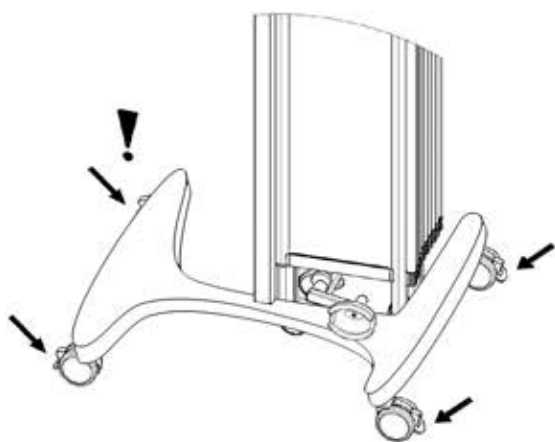

- 3** Bremsen an allen vier Lenkrollen einrasten
Lock the 4 castors by pressing downwards on the lock levers
Actionner les freins des 4 roulettes

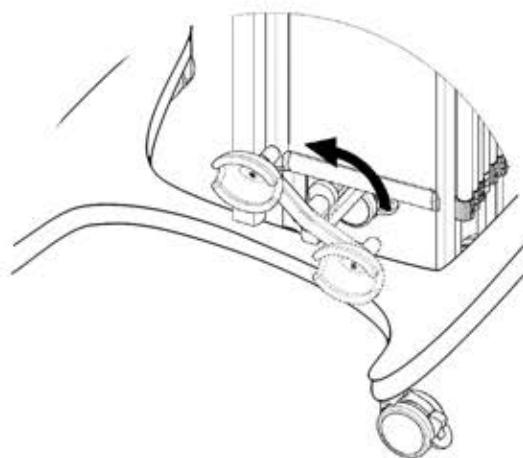

- 4** Arretierung lösen
Unlock the screen using the pedal
Débloquer le système relevateur

Aufstellen der faltwand

Wheel the folding wall into the required location

Placer le paravent rigide

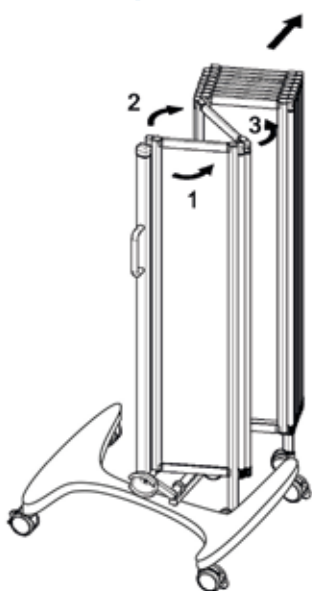

- 5** faltwand vom stützwagen her ausfalten
Open the screen
Ouvrir le paravent

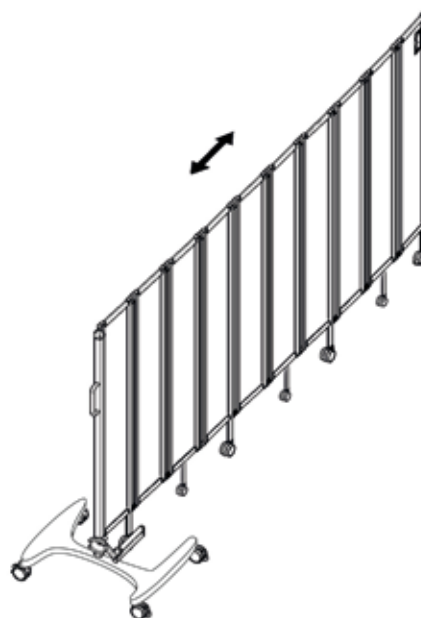

- 6** faltwand ausrichten
Extend the folding wall to the correct position
Orienter le paravent

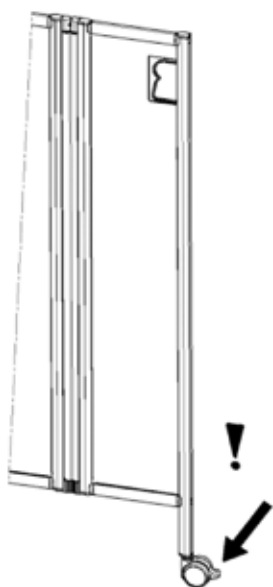

- 7** Alle Bremsen an den Lenkrollen der faltwand einrasten
Lock all castors of the screen
Enclencher le frein de toutes les roues

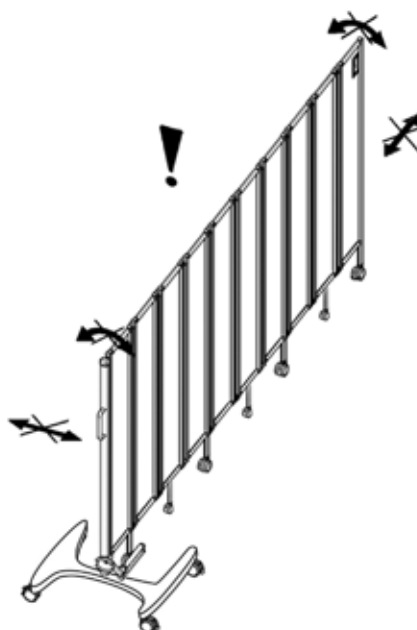

- 8** faltwand nicht mehr verschieben
Do not attempt to move the screen when in the locked position
Ne plus déplacer le paravent

Aufstellen der faltwand

Wheel the folding wall into the required location

Placer le paravent rigide

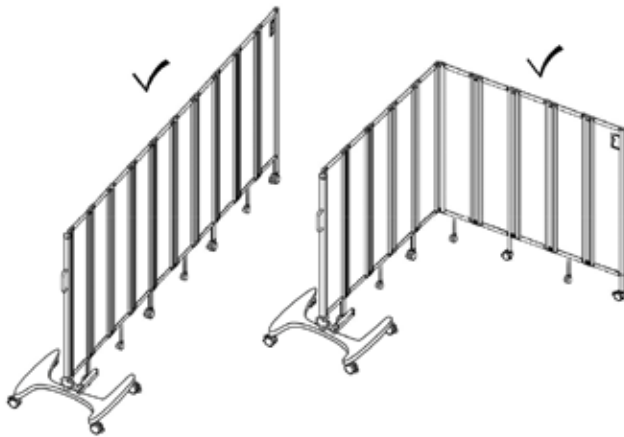

- 1** Zugelassene, stabile Ausrichtungen
Stable and recommended positions
Positions stables et permises

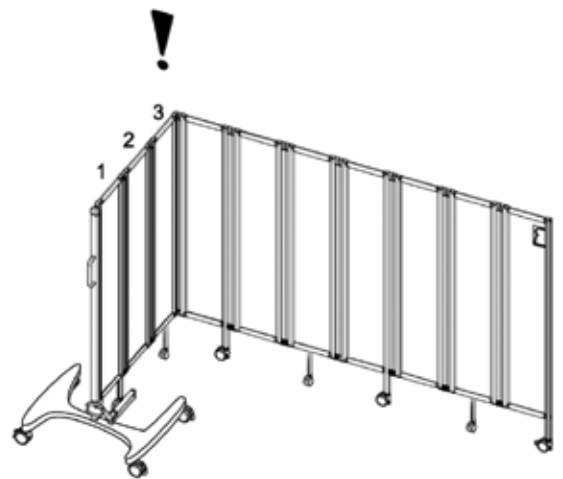

- 2** Mindestens drei Elemente vom Stützwagen aus gerade lassen
Extend a minimum of 3 panels „in-line“, the remaining panels can be extended at right angles, if required
Laisser au minimum les 3 premiers battants alignés puis positionner le reste en angle droit

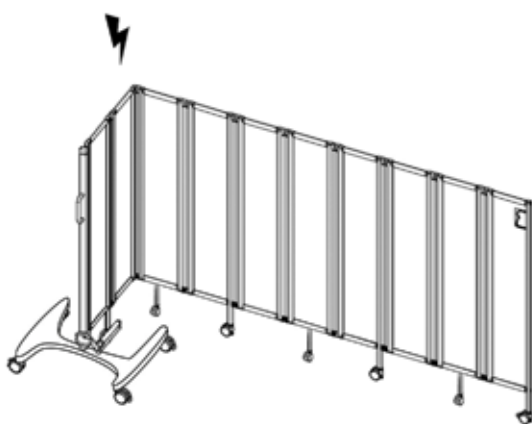

- 3** Unzulässig: zu wenige Elemente vom Stützwagen aus gerade gelassen!
Unstable position : only 1 or 2 panels „in-line“, before forming a right angle
Position déconseillée : aligner trop peu de battants avant l'angle droit.

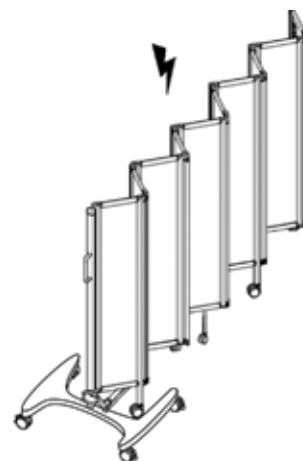

- 4** Unzulässige Aufstellung!
Unstable position
Positions déconseillées

Wichtige Hinweise zur Aufstellung der Faltwand

Important information regarding the positioning of the folding wall

Informations importantes quant à la disposition du paravent

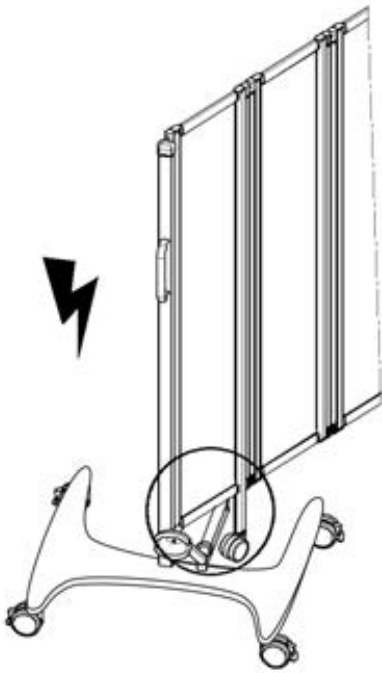

- 5** Unzulässige Stellung des Stützwagens!
Incorrect positioning of the trolley
Mauvais positionnement du piètement !

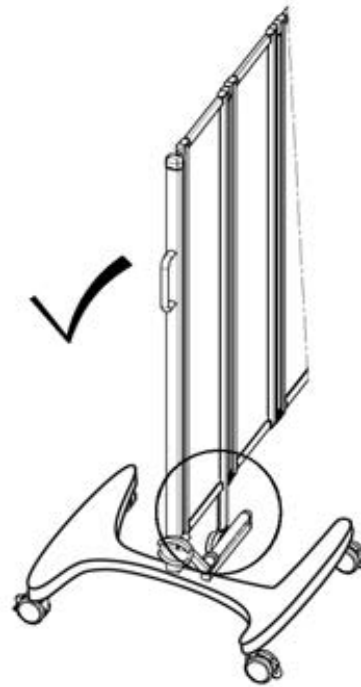

- 6** Korrekte Stellung des Stützwagens
Correct positioning of the trolley
Positionnement correct du piètement

Zusammenfalten der faltwand

Folding the screen away

Rangement du paravent rigide

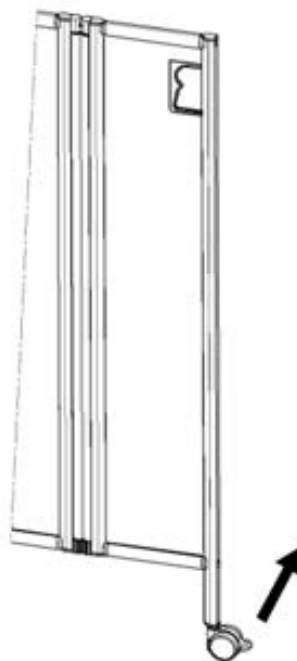

- 1** Bremsen an den Lenkrollen der faltwand lösen
Unlock all castors of the screen
Désenclencher le frein de toutes les roues

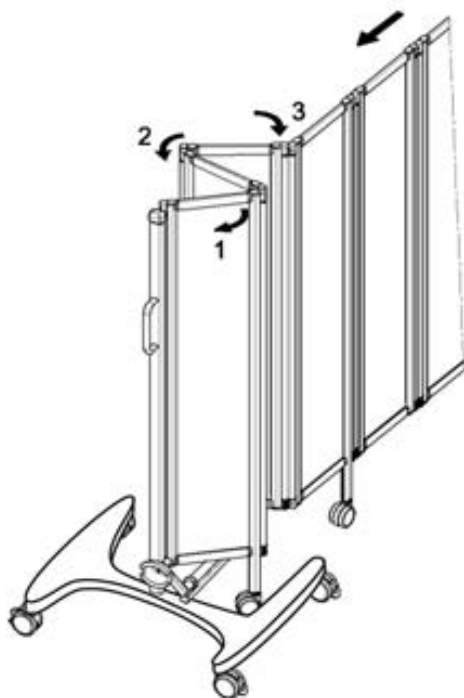

- 2** faltwand vom Stützwagen her zusammenfalten
Fold the panels together onto the trolley
A partir du piètement, rassembler un à un les battants.

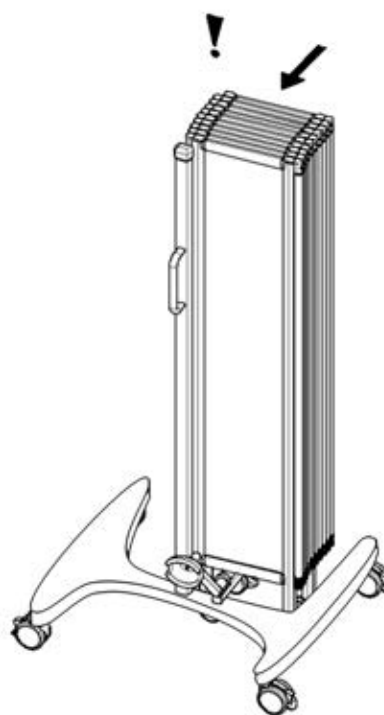

- 3** Paket zusammenschieben
Fold the panels together onto the lifting mechanism
Rassembler les battants sur le système releveur

Zusammenfalten der faltwand

Folding the screen away

Rangement du paravent rigide

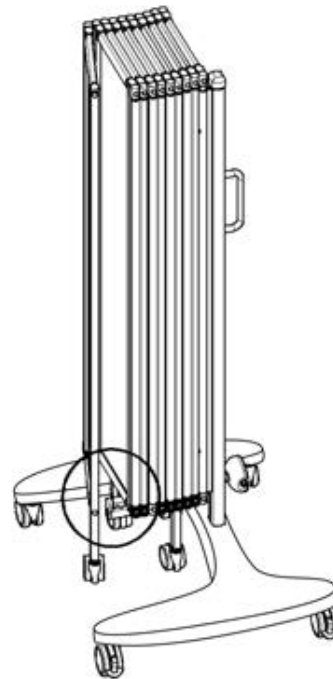

- 4** Unzulässig: Flügel dürfen nicht außerhalb der Arretierung liegen!

Ensure that the panels do not overhang the lifting mechanism

Attention : aucun battant ne doit dépasser du système relevateur

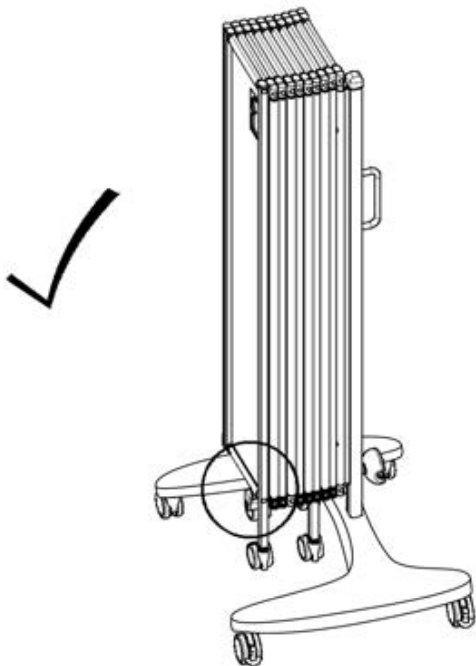

- 5** Korrekt: Alle Flügel sind innerhalb der Arretierung

Correct position : all panels are positioned onto the lifting mechanism

Correct : tous les battants sont positionnés sur le système relevateur

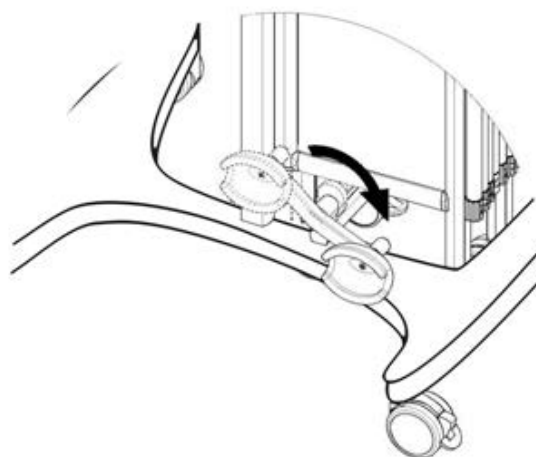

- 6** Arretierung betätigen

Lock the panels into place by pressing the pedal to the right

Bloquer les battants en positionnant la pédale du système relevateur vers votre droite

RFW Faltwand wandmontiert | Paravent rigide montage mural | Folding Wall wall-mounted
RFW-FG Faltwand fahrbar | Paravent rigide Version mobile | Folding Wall mobile version

Montageanleitung | Gebrauchsanweisung | Fehlerhafte Anwendungen | Wartung & Pflege | Technische Daten
Instructions de montage | Notice d'utilisation | Mauvaises manipulations | Maintenance & entretien | Données techniques
Installation instructions | General use | Incorrect Usage | Maintenance & cleaning | Technical Information

Distributed by

puras

031 996 85 85
puras.ch



ROPIMEX R. OPEL GmbH
Bildstocker Str. 12-14 · D-66538 Neunkirchen · Tel. +49 6821 9 12 77-0
Fax +49 6821 9 12 77-99 · info@ropimex.com · www.ropimex.com

ropimex[®]